

## Technical Data

DS 690	
Product Type	Compact embedded Panel PC
General characteristics	
Processor	Intel® Atom™ Processor N270 1.6GHz with 533MHz FSB 512K L2 Cache -- FANLESS
Chipset	Intel® 945GSE + Intel® ICH7M
Memory	512MB to 2GB DDR2 SDRAM SO-DIMM
Expansion slots	1 x PCI Slots
Operating systems	Microsoft Windows 2000/XP/7
Power Supply	90 - 260 VAC fanless
	10 - 36 VDC fanless optional
Power consumption	25 W with 15" LED Monitor
Guarantee	24 Months <sup>1</sup>
Drives	
Mass Memory	2,5" HDD at 60 GB (optional DiskOnModule at 512MB,1GB,2GB or 4GB)
Additional Drives	Compact Flash Reader, optional
Interfaces	
LAN/Ethernet	Dual PCIe Gigabit ethernet controller onboard
USB	7 x USB2.0 (4 x ext., 3 x int)
Serial Interface	5 x RS232 (2 x ext 3 x int), 1 x RS -232/422/485 (ext)
Keyboard/Mouse	2 x PS/2
Video	1 x VGA Port, Supports HD resolution Intel® Graphics Media Accelerator 950 (Intel® GMA 950)
Multimedia	Realtek ALC655 AC'97 Codec
Other Interfaces	Digital I/O 16-bits GPIO (int)
Watchdog Functions	
CPU Temperature	Surveillance onboard
Ambient Conditions	
Vibration resistance	15G
Shock resistance	50G
EMC	EN 55011, 55022, 500081
Temperature	+5°C to +45°C max.
Relative humidity	5% to 80% at 25°C (no humidity/condense)
Authorization	CE
Mechanical Characteristics	
PC Unit	Powder coated, EMC proofed

<sup>1</sup> warranty ex works, normally 24 months, fixed at order.  
All data refer on print date, errors and changes excepted



Front Unit					
Display diagonal size	12"	15"	17"	19"	21"
	30,5 cm	38,1 cm	43,2 cm	48,3 cm	54,1 cm
Resolution	800x600	1024x768	1280x1024		1600x1200
Luminosity [cd/m <sup>2</sup> ]	400	350	300		250
Contrast Ratio	500:1	550:1	700:1	800:1	500:1
MTBF backlight [h]	50.000				
Input	Resistive Touchscreen, 6-wire technology				
Touchcontroller	Alternatively USB or RS232				
Front	Alloy anodised, chemical resistant polyester foil				
Rating	IP65 according EN 60529				
Dimensions [mm]					
a:	400	460	472	540	
b:	310	360	383	440	
c:	90	95		110	
d:	370	429	440	509	
e:	290	337	363	406	
Weight	ca. 10 kg	ca. 12kg	ca. 13kg	ca. 15kg	

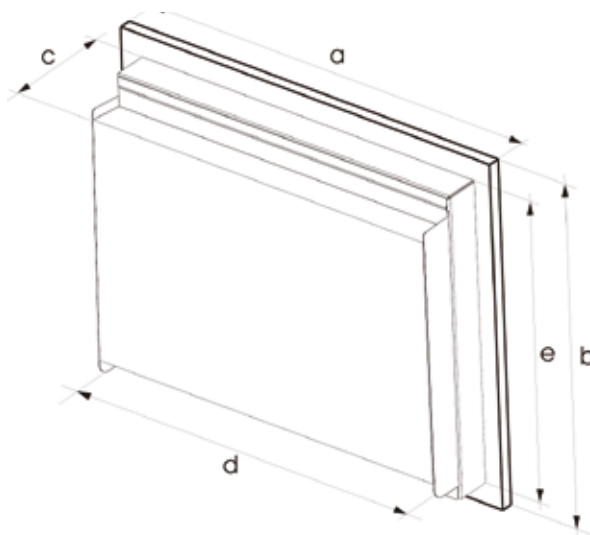

### Highlights

- Ultra LOW power requirements
- HIGH performance
- Intel ATOM processor
- 1 PCI slot
- Fanless, passive air conduction
- Long life LED backlight Display
- Low mounting depth
- High power efficiency
- High performance
- Dual display architecture
- DUAL Gigabit LAN



### DS 690 Configuration

	1	2	3	4	5	6	7	8
<b>Monitor</b>								
30,5 cm 12" TFT Display, 800x600 Pixel	1							
38,1 cm 15" TFT Display, 1024x768 Pixel, LED Backlight	2							
43,2 cm 17" TFT Display, 1280x1024 Pixel	3							
48,3 cm 19" TFT Display, 1280x1024 Pixel	4							
54,1 cm 21" TFT Display, 1600x1200 Pixel	5							
<b>Processor</b>								
Intel® Atom™ Processor N270 1.6GHz	2							
<b>Memory</b>								
512 MB			3					
1 GB			4					
2 GB			5					
<b>Storage</b>								
HDD 2.5" min 60 GB						1		
DiscOnModule 512 MB						3		
DiscOnModule 1 GB						4		
DiscOnModule 2 GB						5		
DiscOnModule 4 GB						6		
DiscOnModule 8 GB						7		
<b>Drives</b>								
No drives						0		
CFC-Adapter						1		
<b>Power</b>								
110/230 VAC, auto-switch fanless							1	
9 - 28 VDC fanless							2	
<b>Front</b>								
DIVUS foil								0
neutral, 1 colors								1
customized <sup>1</sup>								2
<b>Operating system</b>								
Microsoft Windows 2000 Prof. MUI								A
Microsoft Windows XP Prof. MUI								L
Microsoft Windows 7 Prof. English								M
Microsoft Windows 7 Ult. MUI								O
No operating System								0

Your order code: **DS 690**



<sup>1</sup> Frontfoil: min. delivery 25 pcs

### Optional

**V<sub>2</sub>A** Stainless steel front available on 15" and 19" panels

