

Technical Data

| | |
|----------------------------|--|
| DS 691 | |
| Product Type | Compact embedded Panel PC |
| General characteristics | |
| Processor | Intel® Atom™ Processor N270 1.6GHz with 533MHz FSB 512K L2 Cache -- FANLESS |
| Chipset | Intel® 945GSE + Intel® ICH7M |
| Memory | 512MB to 2GB DDR2 SDRAM SO-DIMM |
| Expansion slots | 2 x PCI Slots |
| Operating systems | Microsoft Windows 2000/XP/7 |
| Power Supply | 90 - 260 VAC fanless 10 - 36 VDC fanless optional |
| Power consumption | 25 W with 15" LED Monitor |
| Guarantee | 24 Months ¹ |
| Drives | |
| Mass Memory | 2,5" HDD at 60 GB (optional DiskOnModule at 512MB,1GB,2GB or 4GB) |
| Optical Drives | optional CD-Rom or DVD/CD-RW drive, rear side operation |
| Additional Drives | Compact Flash Reader, optional |
| Interfaces | |
| LAN/Ethernet | Dual PCIe Gigabit ethernet controller onboard |
| USB | 7 x USB2.0 (4 x ext., 3 x int) |
| Serial Interface | 5 x RS232 (2 x ext 3 x int), 1 x RS -232/422/485 (ext) |
| Keyboard/Mouse | 2 x PS/2 |
| Video | 1 x VGA Port, Supports HD resolution Intel® Graphics Media Accelerator 950 (Intel® GMA 950) |
| Multimedia | Realtek ALC655 AC'97 Codec |
| Other Interfaces | Digital I/O 16-bits GPIO (int) |
| Watchdog Functions | |
| CPU Temperature | Surveillance onboard |
| Ambient Conditions | |
| Vibration resistance | 15G |
| Shock resistance | 50G |
| EMC | EN 55011, 55022, 500081 |
| Temperature | +5°C to +45°C max. |
| Relative humidity | 5% to 80% at 25°C (no humidity/condense) |
| Authorization | CE |
| Mechanical Characteristics | |
| PC Unit | Powder coated, EMC proofed |

¹ warranty ex works, normally 24 months, fixed at order.
All data refer on print date, errors and changes excepted



| | | | | | |
|---------------------------------|---|----------|-----------|----------|-----------|
| Front Unit | | | | | |
| Display diagonal size | 12" | 15" | 17" | 19" | 21" |
| | 30,5 cm | 38,1 cm | 43,2 cm | 48,3 cm | 54,1 cm |
| Resolution | 800x600 | 1024x768 | 1280x1024 | | 1600x1200 |
| Luminosity [cd/m ²] | 400 | 350 | 300 | | 250 |
| Contrast Ratio | 500:1 | 550:1 | 700:1 | 800:1 | 500:1 |
| MTBF backlight [h] | 50.000 | | | | |
| Input | Resistive Touchscreen, 6-wire technology | | | | |
| Touchcontroller | Alternatively USB or RS232 | | | | |
| Front | Alloy anodised, chemical resistant polyester foil | | | | |
| Rating | IP65 according EN 60529 | | | | |
| Dimensions [mm] | | | | | |
| a: | 400 | 460 | 472 | 540 | |
| b: | 310 | 360 | 383 | 440 | |
| c: | 115 | 120 | | 135 | |
| d: | 370 | 429 | 440 | 509 | |
| e: | 290 | 337 | 363 | 406 | |
| Weight | ca. 10 kg | ca. 12kg | ca. 13kg | ca. 15kg | |

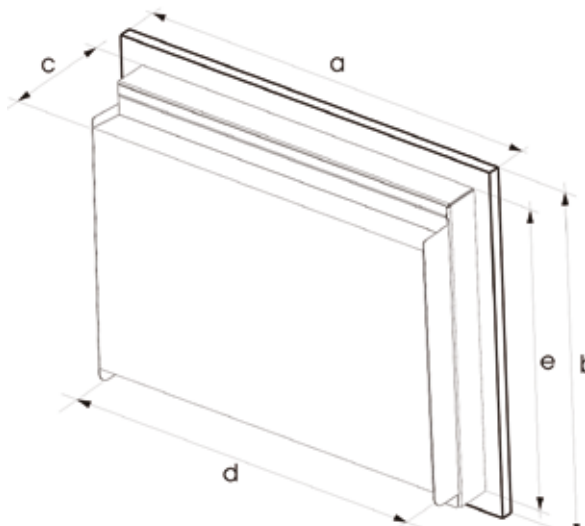

Highlights

- Ultra LOW power requirements
- HIGH performance
- Intel ATOM processor
- 2 PCI Slots
- Fanless, passive air conduction
- Long life LED backlight Display
- Low mounting depth
- High power efficiency
- High performance
- Dual display architecture
- DUAL Gigabit LAN

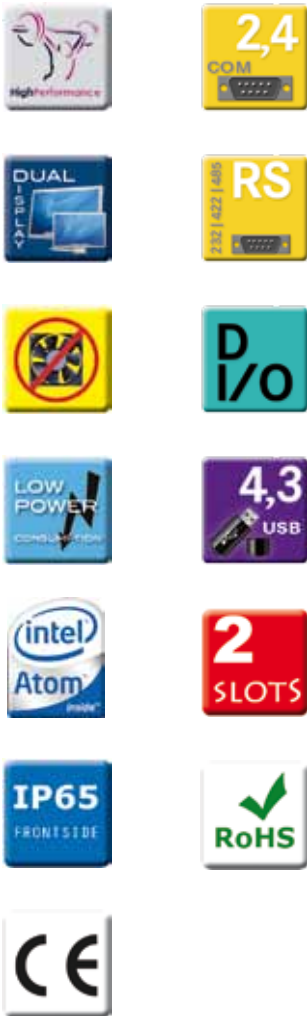

DS 691 Configuration

| | 1 | 2 | 3 | 4 | 5 | 6 | 7 | 8 |
|--|---|---|---|---|---|---|---|---|
| Monitor | | | | | | | | |
| 30,5 cm 12" TFT Display, 800x600 Pixel | 1 | | | | | | | |
| 38,1 cm 15" TFT Display, 1024x768 Pixel, LED Backlight | 2 | | | | | | | |
| 43,2 cm 17" TFT Display, 1280x1024 Pixel | 3 | | | | | | | |
| 48,3 cm 19" TFT Display, 1280x1024 Pixel | 4 | | | | | | | |
| 54,1 cm 21" TFT Display, 1600x1200 Pixel | 5 | | | | | | | |
| Processor | | | | | | | | |
| Intel® Atom™ Processor N270 1.6GHz | | 2 | | | | | | |
| Memory | | | | | | | | |
| 512 MB | | | 3 | | | | | |
| 1 GB | | | 4 | | | | | |
| 2 GB | | | 5 | | | | | |
| Storage | | | | | | | | |
| HDD 2.5" min 60 GB | | | | | | 1 | | |
| DiscOnModule 512 MB | | | | | | 3 | | |
| DiscOnModule 1 GB | | | | | | 4 | | |
| DiscOnModule 2 GB | | | | | | 5 | | |
| DiscOnModule 4 GB | | | | | | 6 | | |
| DiscOnModule 8 GB | | | | | | 7 | | |
| Drives | | | | | | | | |
| No drives | | | | | | | 0 | |
| CFC-Adapter | | | | | | | 1 | |
| CD ROM, slim Drive | | | | | | | 2 | |
| COMBO DVD/CD ROM R/W, slim Drive | | | | | | | 3 | |
| CD ROM, slim Drive+CFC-Adapter | | | | | | | 4 | |
| COMBO DVD/CD ROM R/W, slim Drive + CFC-Adapter | | | | | | | 5 | |
| Power | | | | | | | | |
| 110/230 VAC, auto-switch fanless | | | | | | | 1 | |
| 9 - 28 VDC fanless | | | | | | | 2 | |
| Front | | | | | | | | |
| DIVUS foil | | | | | | | | 0 |
| neutral, 1 colors | | | | | | | | 1 |
| customized ¹ | | | | | | | | 2 |
| Operating system | | | | | | | | |
| Microsoft Windows 2000 Prof. MUI | | | | | | | | A |
| Microsoft Windows XP Prof. MUI | | | | | | | | L |
| Microsoft Windows 7 Prof. English | | | | | | | | M |
| Microsoft Windows 7 Ult. MUI | | | | | | | | O |
| No operating System | | | | | | | | 0 |

Your order code: **DS 691**



NOTES:
¹ Frontfoil: min. delivery 25 pcs

Optional

V₂A Stainless steel front available on 15" and 19" panels