

Technical Data

DIVUS STEEL	
Product Type	Embedded Stainless Steel Integrale PC - IP 65 all around
General characteristics	
Processor	Intel® Atom™ Processor N270 1.6GHz with 533MHz FSB 512K L2 Cache -- FANLESS
Chipset	Intel® 945GSE + Intel® ICH7M
Memory	512MB to 2GB DDR2 SDRAM SO-DIMM
Expansion slots	N/A
Operating systems	Microsoft Windows XP embedded, Windows Embedded Standard
Power Supply	90 - 260 VAC fanless
	10 - 36 VDC fanless optional
Power consumption	30 W with 15" LED Monitor
Guarantee	24 Months ¹
Drives	
Mass Memory	DOM (Disk On Module) at 512MB (1, 2, 4 and 8GB optional)
Additional Drives	Compact Flash Reader onboard
Interfaces	
LAN/Ethernet	Dual PCIe Gigabit ethernet (2 x on VESA connection, optional 1 x IP65 RJ45 externally accessible on bottom; code S-RJ45)
USB	3 x USB2.0 (3 x on VESA connection, optional 1 USB IP65 externally accessible on bottom; code: S-USB)
Serial Interface	2 x RS232 (on VESA connection), optional 1 of them preconfigured to RS422 or RS485
Keyboard/Mouse	optional Keyboard system with touchpad optional with RFID see additional Datasheet DIVUS STEEL Keyboard System
Video	Intel® Graphics Media Accelerator 950
Multimedia	Realtek ALC655 AC'97 Codec (line out, mic in, spk out on VESA connection)
Power Button	1 external power button on bottom side
Watchdog Functions	
CPU Temperature	Surveillance onboard
Ambient Conditions	
Vibration resistance	15G
Shock resistance	50G
EMC	EN 55011, 55022, 500081
Temperature	+5°C to +45°C max.
Relative humidity	5% to 80% at 25°C (no humidity/condense)
Authorization	CE
Mechanical Characteristics	
PC Unit	Stainless steel V2A

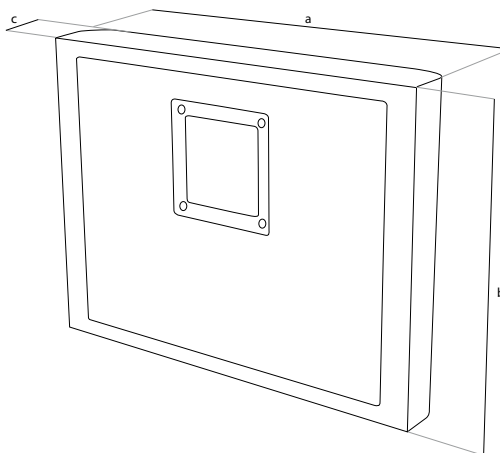

Front Unit		
Display diagonal size	38,1 cm 15" LED backlight	48,3 cm 19"
Resolution	1024x768	1280x1024
Luminosity [cd/m²]	350	300
Contrast Ratio	550:1	800:1
MTBF backlight [h]	50.000	
Input	Resistive Touchscreen, 6-wire technology	
Touchcontroller	USB	
Rating	IP65 all around according EN 60529	
Mounting		
- by default DIVUS STEEL meets VESA 100 Standard - Type: MIS-D 100 - Distance between screw centers: 100 mm × 100 mm - Screws needed: M4		
Dimensions [mm]		
a:	440	530
b:	330	424
c:	65	76
Weight	ca.10kg	ca. 13 kg



¹ warranty ex works, normally 24 months, fixed at order.-
All data refer on print date, errors and changes excepted

Highlights

- Stainless steel housing (V2A)
- Meets food plant hygiene standards
- IP65 around
- Interface pass through using VESA 100 connection
- Ultra LOW power requirements
- HIGH performance
- Intel ATOM processor
- Fanless, passive air conduction
- Motionless, no moving parts
- Long life LED backlight Display
- Low mounting depth
- High power efficiency
- High performance
- Intel PRO Chipset
- Dual display architecture
- DUAL Gigabit LAN



DIVUS STEEL Configuration

	1	2	3	4	5	6	7	8
Monitor								
38,1 cm 15" TFT Display, 1024x768 Pixel, LED Backlight		2						
48,3 cm 19" TFT Display, 1280x1024 Pixel		4						
Processor								
Intel® Atom™ Processor N270 1.6GHz		2						
Memory								
512 MB			3					
1 GB			4					
2 GB			5					
Storage								
Hard Disk 20 GB					1			
DiscOnModule 512 MB					3			
DiscOnModule 1 GB					4			
DiscOnModule 2 GB					5			
DiscOnModule 4 GB					6			
DiscOnModule 8 GB					7			
Industrial Flash Disk 16 GB					8			
Industrial Flash Disk 32 GB					9			
Additional Memory								
No drives					0			
CF-Card 2 GB (up to 8 GB)					x			
Power								
110/230 VAC, auto-switch fanless							1	
24 VDC fanless							2	
Front Design								
DIVUS							0	
customized ¹							2	
Operating system								
Microsoft Windows XP Embedded								S
Microsoft WE7E English ²								T
Microsoft WE7P MUI ³								U

Your order code: **D-STEEL**



¹ Customization: min. delivery 50 pcs
² Preconfigured - specify on order
³ Windows Embedded Standard requires 1 GB memory



Keyboard System

RFID Keyboard System

DIVUS STEEL Keyboard System prepared to work with your preferred RFID standard

- Full standard keyboard (German layout)
- Touchpad integrated
- IP 65 All around
- meets food plant hygiene standards
- Integrated in DIVUS STEEL mechanics
- prepared to contain customers RFID standard



Standard Keyboard system

DIVUS STEEL Keyboard System Standard

- Full standard keyboard (German layout)
- Touchpad integrated
- IP 65 All around
- meets food plant hygiene standards
- Integrated in DIVUS STEEL mechanics



Optionals

BASE	
<p>DIVUS STEEL mounting example</p> <ul style="list-style-type: none">- High quality V2A base for freestanding DIVUS STEEL positioning- Measures::	
S_USB	
<p>USB Interface external, IP65, cable lenght 0,6m</p>	
S_RJ45	
<p>RJ45 Interface external, IP65, cable lenght 0,6m</p>	